



724 DOUBLE RACK GAS OVEN

Available in gas, oil or electrically heated models.
Accepts: 2 single racks (18" x 26" pans)
or 1 double rack (18" x 26" pans or 20" x 30" pans).

Revent TCC System (Total Convection Control)
Revent HVS System (High Volume Steam)

*Revent's line of innovative baking technology is made to
take any bread to the highest level. In bread we trust.*



In Bread We Trust

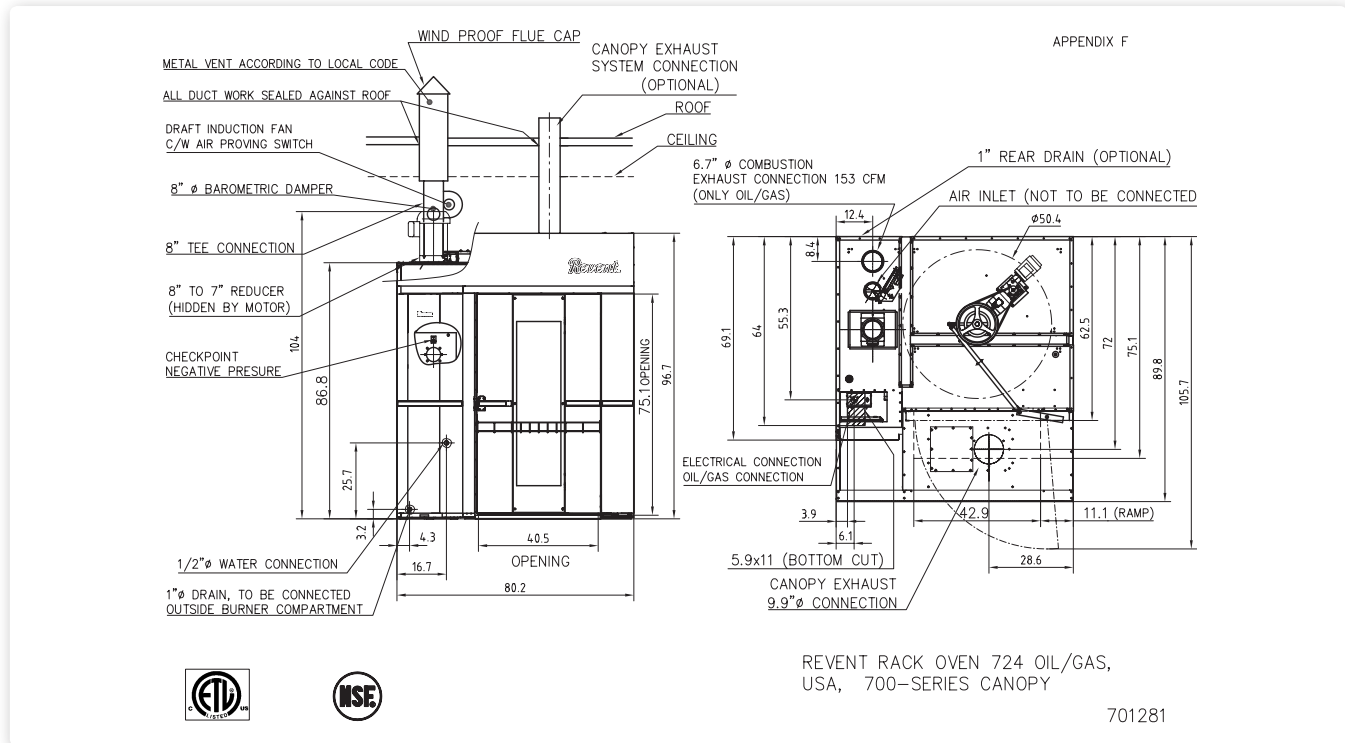

Standard features

- > Revent TCC System
- > Revent HVS System
- > Revent LID System
- > Revent Cross Line Heat Exchanger
- > Revent Wedge Installation System
- > Stainless Steel Design
- > GIAC (Graphic InterActive Control) Panel
- > Automatic Steam and Damper Control
- > Double glass door

Utility Requirements

Gas

- > Natural Gas: Indirect fired 1" drop to 3/4" NPT connection
- > Liquid Propane: Indirect fired 3/4" drop to 3/4" NPT connection

Water and Drain

- > Water Supply : 1/2" NPT ϕ 60-65 PSI cold
- > Drain: 1" NPT, optional connection to rear

Ventilation

- > Over Pressure Duct:
 - Through door to canopy
- > Oven Damper Exhaust:
 - Through door to canopy
- > Canopy Port: 9.9" ϕ
- > Smoke Exhaust : 6.7" ϕ gas and oil only

Technical information

- > Maximum Heat Capacity: see table below
- > Temperature range: 95-572 °F
- > Total shipping weight: 4200 lbs*
- > Minimum intake opening: 34.5" x 69.3" (standard 3 section delivery)
- > Minimum intake opening: 69.3" x 80.3" (optional – one piece shipment)
- > Minimum section tilt up height: 112.2" (without motor)
- > Swing diameter: 50.39"
- > Max load of racklift and platform 882 lbs
- > Steam Generation 1.85gals/20sec at 482°F
- > Installation requirements: The oven must be installed on level noncombustible floor. The oven may be installed flush against a wall - only the front and top need to be left for access. The space on top of the oven must be well ventilated. The temperature may not exceed 120°F to avoid damage to electric components.

724 Oil/gas heated

Voltage	Heating	Fuse
3PH 208-220V+N	343000 btuh	30 A
3PH 440-480V + 1 PH 115V	343000 btuh	15 A

NOTE:

Other voltages available, check with factory.
Limited warranty, one year parts+labor

*Final shipping

Weights will depend on the final order specifications. Continuous product development is a Revent policy. Therefore, we reserve the right to change specifications and/or design without prior notice. Pictures or drawings may include product options.

Revent sales representative:



Revent Incorporated
100 Ethel Road West, Piscataway, New Jersey 08854
Phone (732) 777-9433, Fax (732) 777-1187
Toll Free 800-822-9642
E-mail info@revent.com, www.revent.com